

Electricity
Distribution

Distributed Generator Owner / Operator Forum

Online Check In / Discussion

25th April 2024

nationalgrid

regen 
transforming energy



Distributed Generation Owner Operator Forum

A regular forum aimed at owner and operators of MW scale generation connected to NGED's network.

An opportunity for DG owner and operators to engage with NGED, contribute towards improved processes and tackle arising issues.

Has been active for over 7 years, NGED were one of the first, others now exist for other DNOs.

Areas covered include:

- Planned outages and NGET plans
- Repowering process (inc G99 and replacing assets)
- Flexibility services and opportunities for connected generators
- Communication pathways (inc DG Owner Operator portal)

Website with past forums:

<https://yourpowerfuture.nationalgrid.co.uk/our-engagement-groups/connection-customer-engagement/distributed-generation-owner-operator-forum>

How many MW of distribution connected energy generation does your organisation currently manage/own in the UK?

17 responses

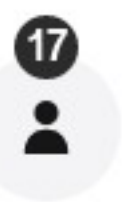
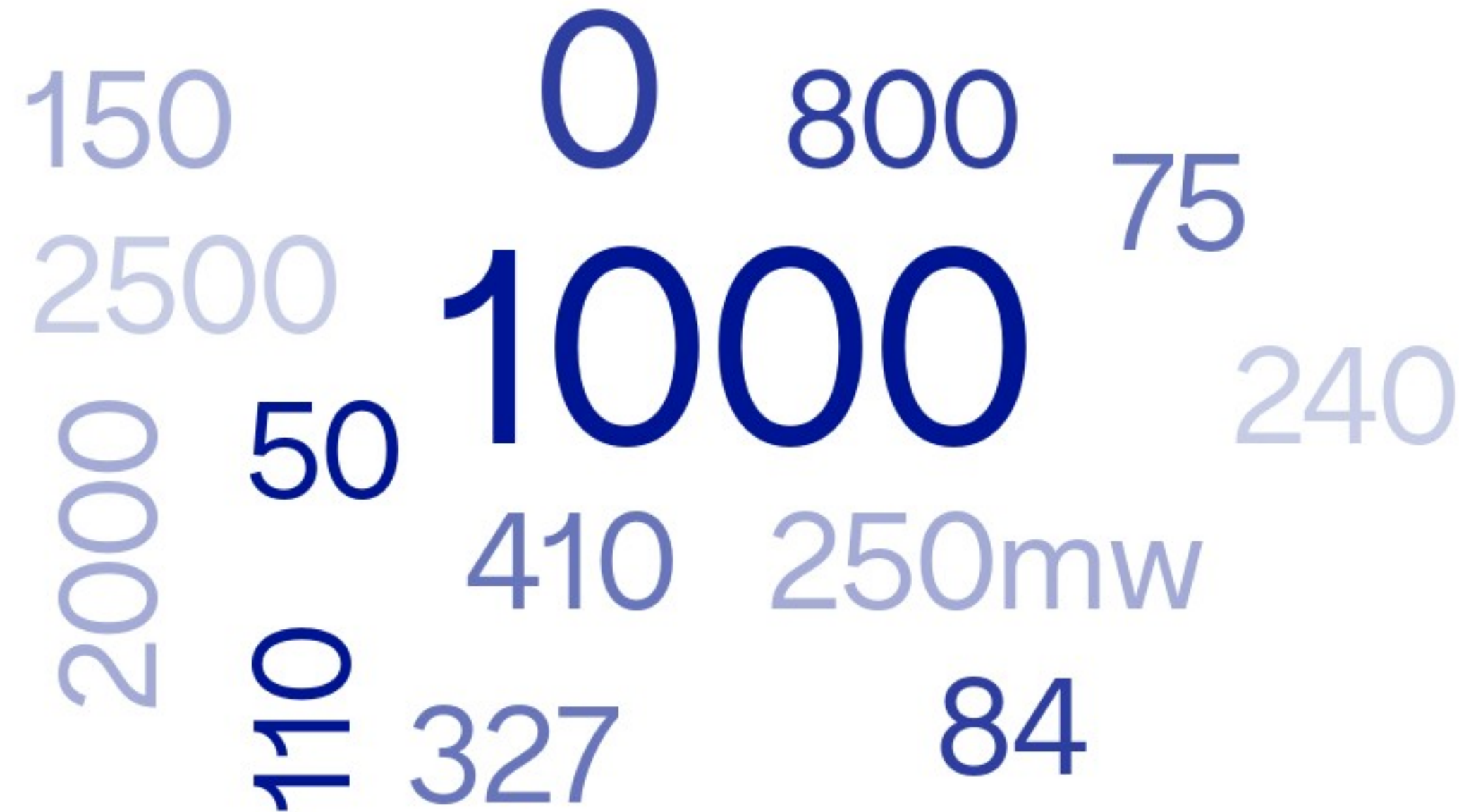

Agenda

10.00 Introductions

Hannah Stanley, stakeholder manager, Regen

10.05 Outage planning update

Danielle Greedy, control support engineer, National Grid Electricity Distribution

10.20 Portal feedback and updates

Joe Davey, DSO energy management centre engineer, National Grid

10.40 2024 objective setting

Hannah Stanley, stakeholder manager, Regen

11.00 Meeting close

National Grid Electricity Distribution Outages 2023

NGET & NGED now in '2024/25 Outage Season'.

Current Number of Upcoming Planned Outages per License Area (Ongoing, Approved, Provisional & Submitted);

- South West – 606
- South Wales – 466
- East Midlands – 751
- West Midlands – 548

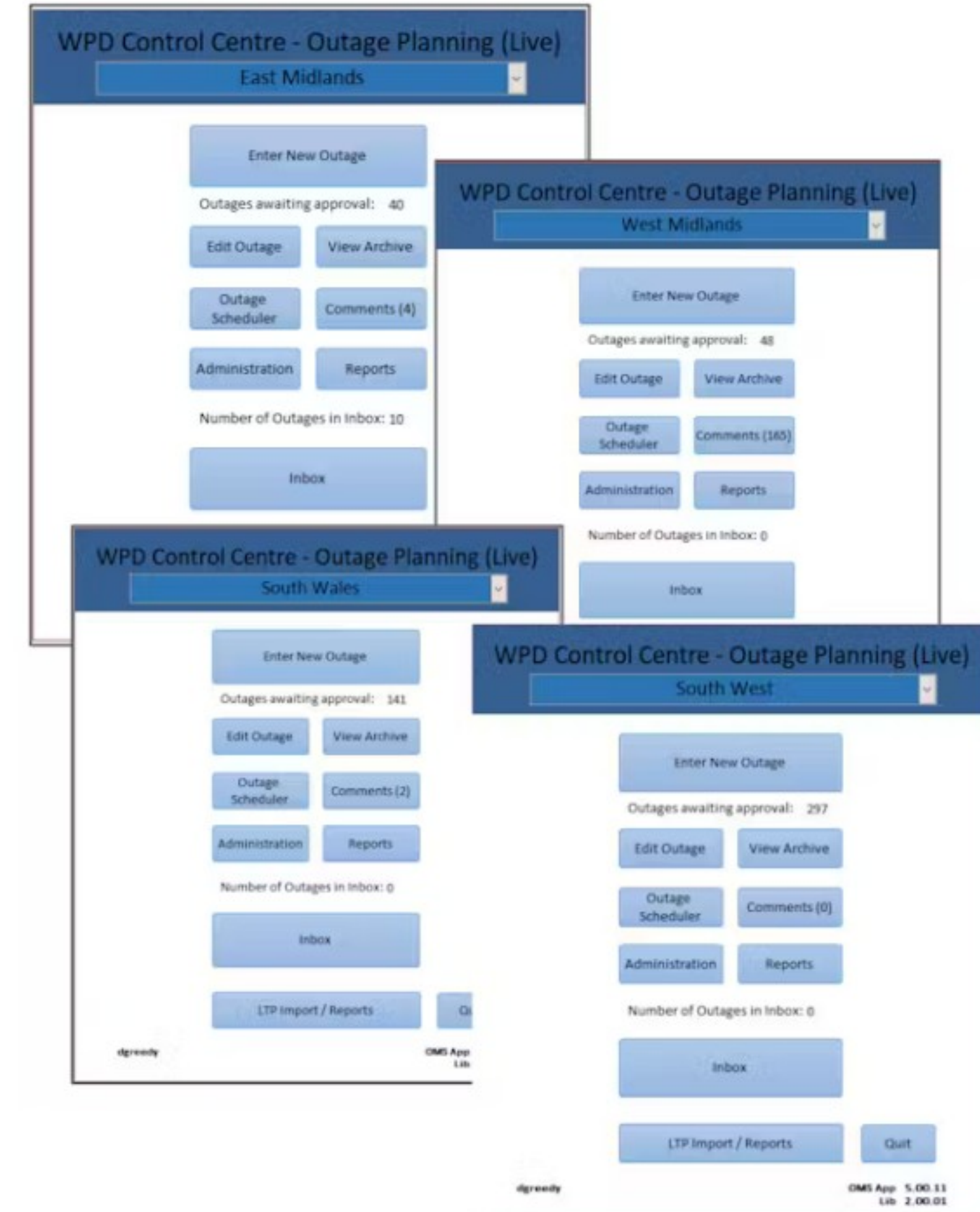



Electricity
Distribution

Distributed Generator Owner / Operator Forum

Outage planning update

Danielle Greedy
Control support engineer
National Grid Electricity Distribution

nationalgrid

regen 
transforming energy

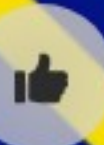

NGED Major Works / Outages

South West

Seabank / Sandford 132kV Reconfiguration;

- Started in 2017. Completion due for 2024.
- Included new Sandford 400/132kV GSP.

Included redirection of two 132kV OH lines which would have required significant curtailment of three connected 33kV DG sites.

Outages studied by our Primary Network Design department which resulted in a elimination / reduction in curtailment due to other generators not yet connected to the network.

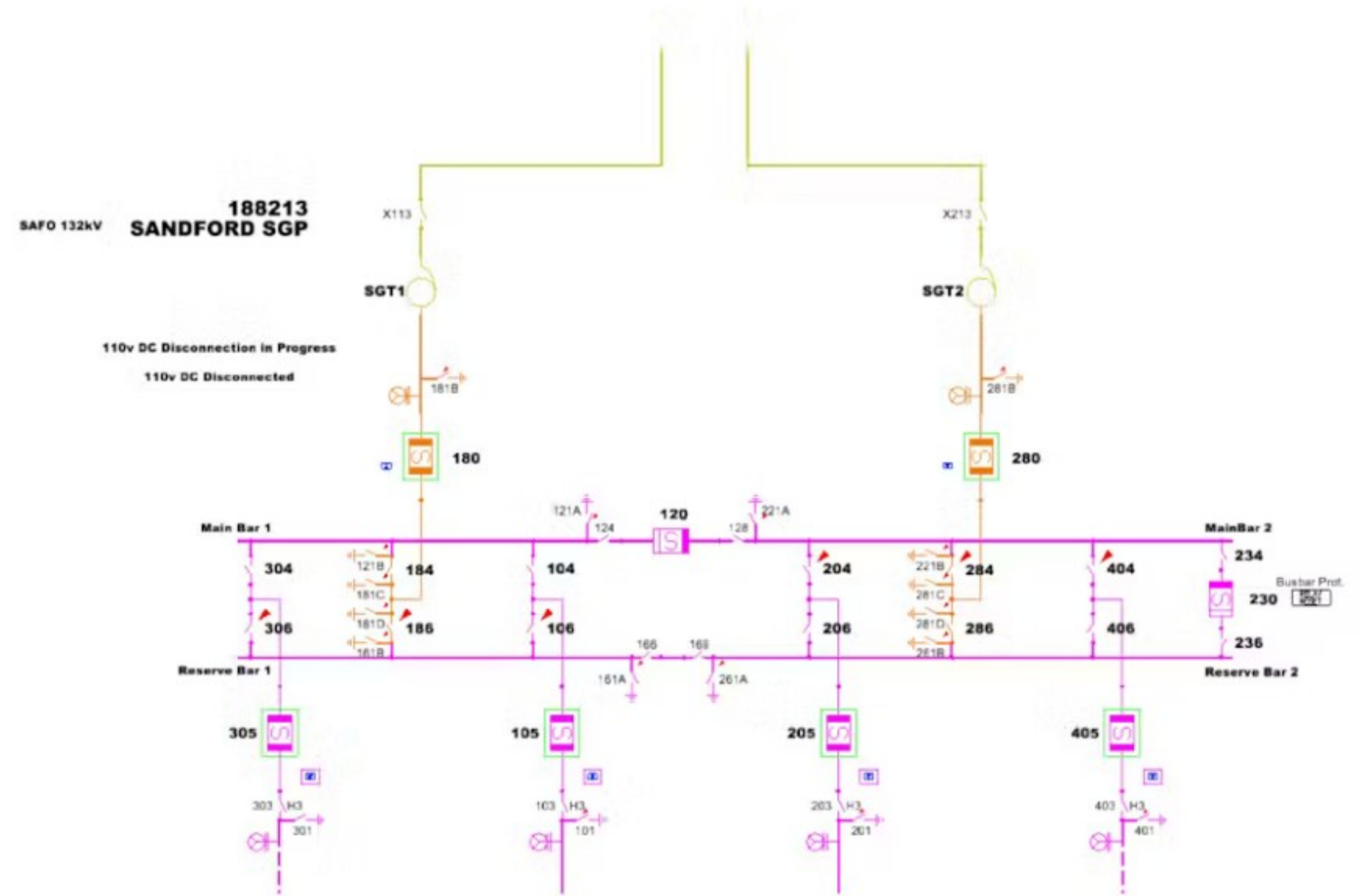

NGED Major Works / Outages

South Wales

Upper Boat GSP Rebuild.

Included replacement of existing 33kV switchboard and all associated interplant cables.

Installed telecontrollable 33kV switch on our network to eliminate extensive curtailment of a 33kV connected solar park.

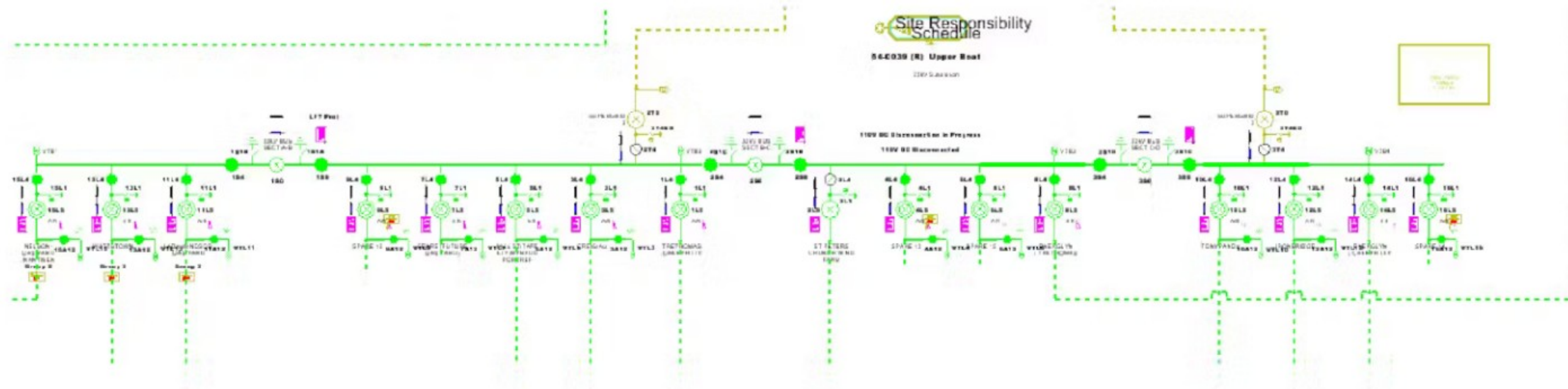

NGED Major Works / Outages

East Midlands

Staythorpe – Cotham Grange – Grantham North

Upcoming planned 132kV OH line refurbishment.

Project requires full outage of a 132kV connected solar park (site is connected in the 'dead zone' so no other options).

Projects Engineer in discussions with customer to look at ways to reduce impact of outage;

- Working evenings / weekends to reduce outage length.
- Breaking jumpers (if possible depending on network design).

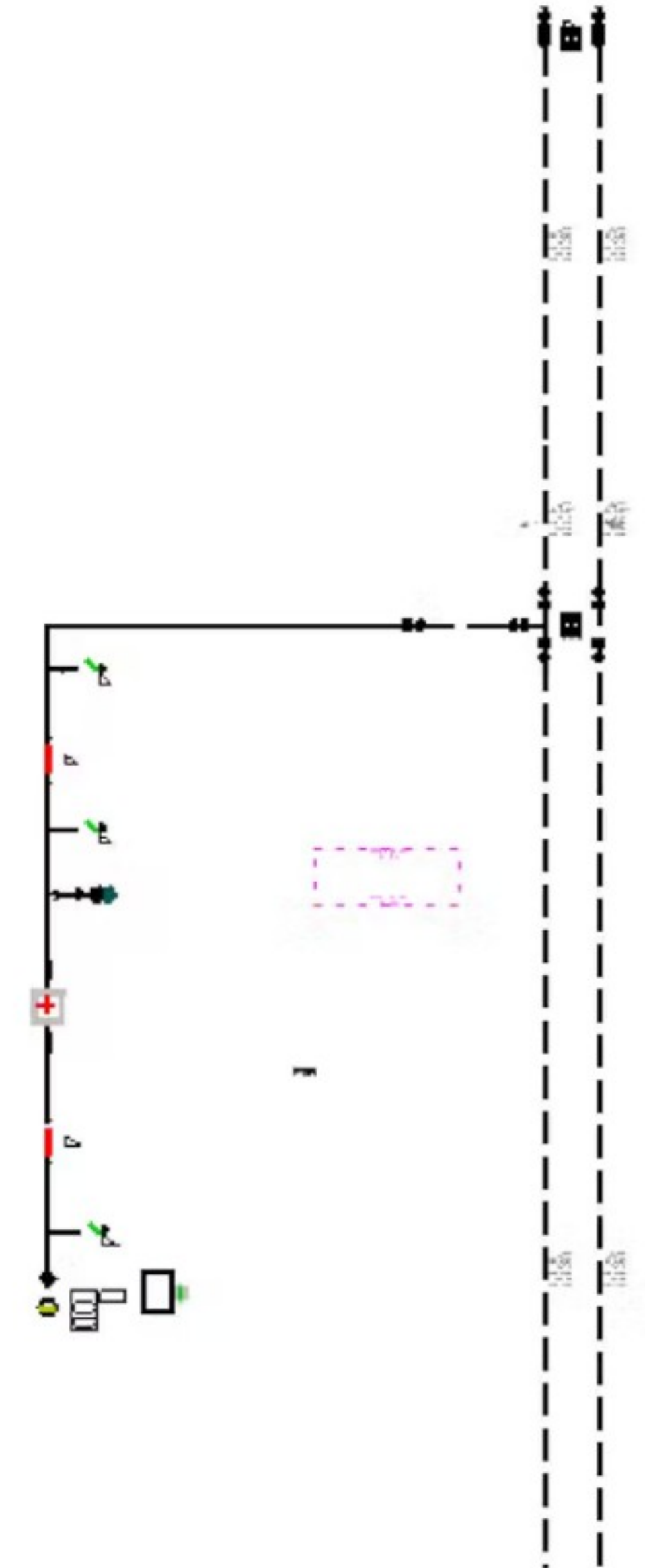

NGED Major Works / Outages

West Midlands

Meaford 33kV Substation

- New GT & extension of 33kV busbars to facilitate connection of new DG site.
Proposed to install several spare 33kV breakers to allow for future connections / network reinforcement.

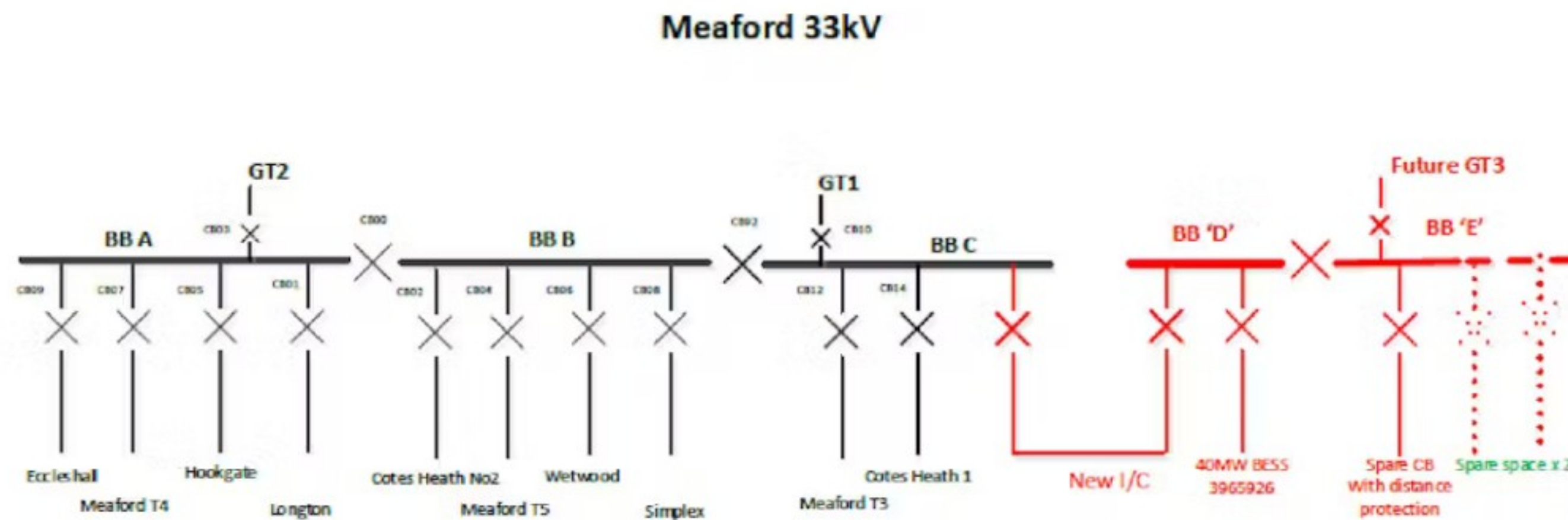

Once project is confirmed, outages will be submitted by Local Area teams.

Outage planner will determine if any DG site curtailment / outages are required.

If outages are for significant length of time, our DSO team can undertake bespoke outage specific studies to see if curtailment levels can be improved / lifted.

Any questions

?



Electricity
Distribution

Distributed Generator Owner / Operator Forum

Portal feedback and updates

Joe Davey
DSO energy management centre engineer
National Grid

nationalgrid

regen 
transforming energy

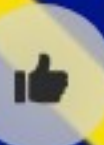

NGED DG Portal

- Originally planned for 2023.
- Postponed due to other work commitments.
- Planned for 2024/25 work stream.



Please rank the existing portal functions in order from most to least useful

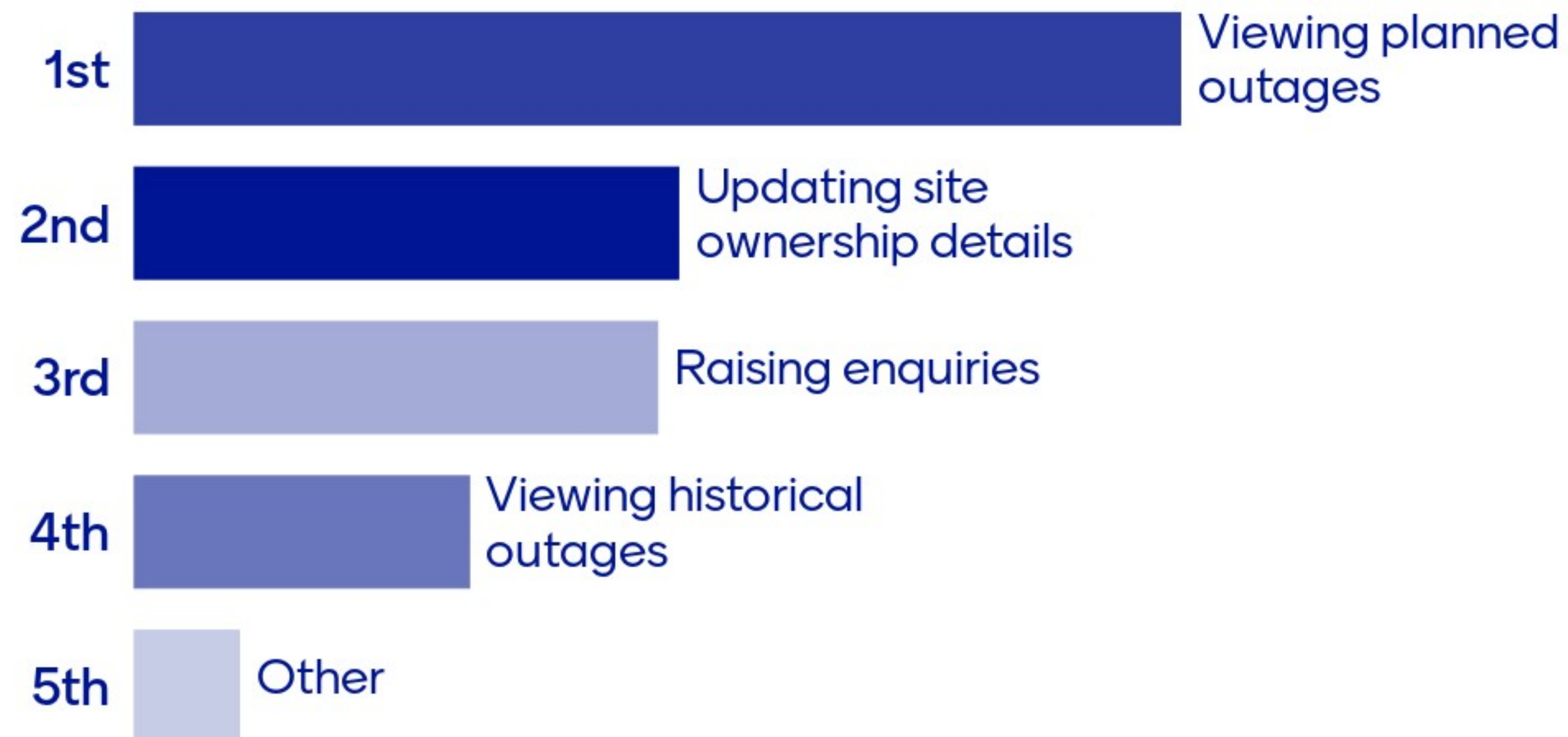

How often do you use the current DG portal?

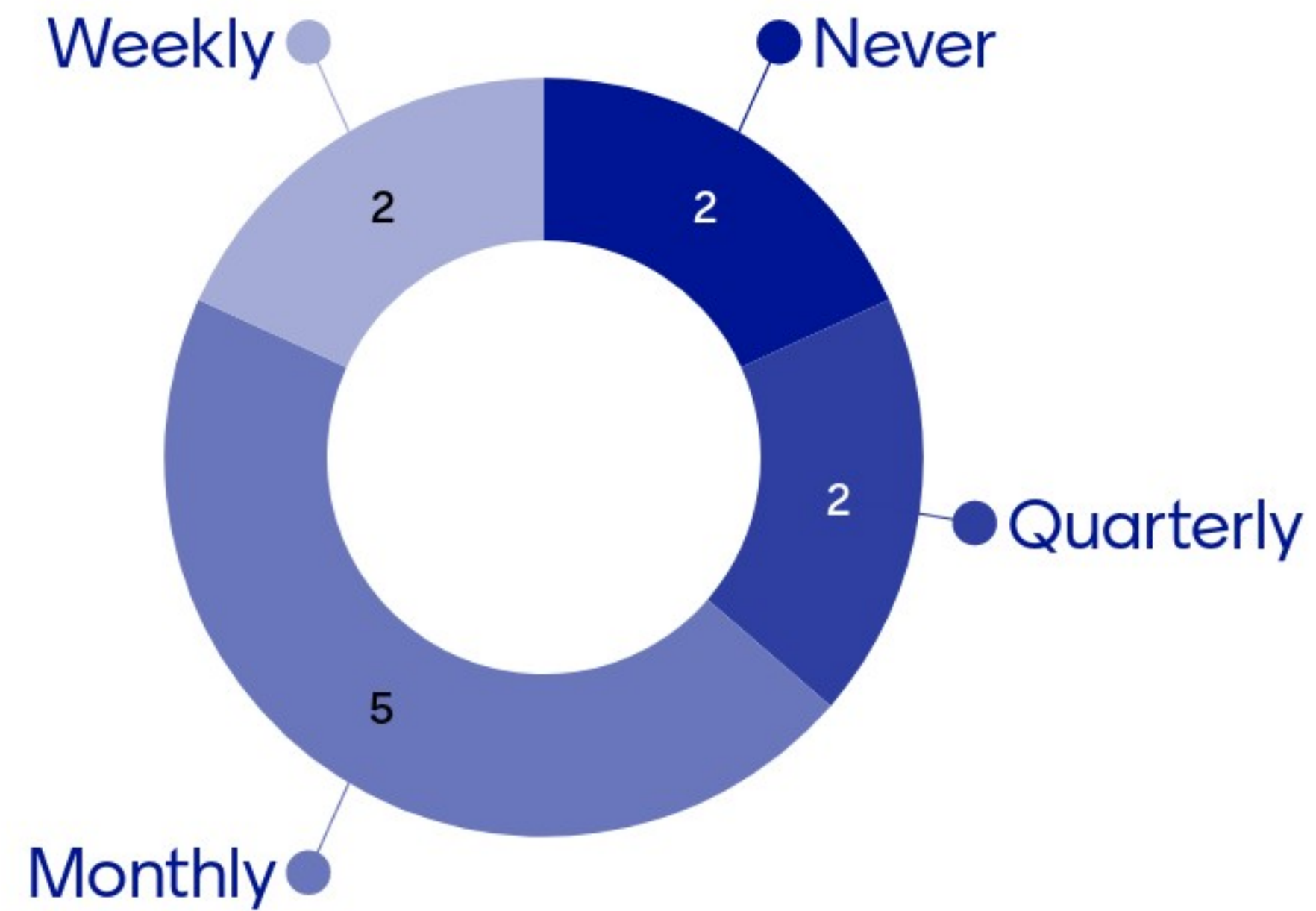

What new functionality would you be interested in?

Future flexibility requirements

Crime reporting? Theft of cable in a particular area

Can we see other sites outages in the surrounding area?

Programme with dates of expected tenders, outages, events, etc.

Greater detail on outage cause and programs

Live view of connections queue

Live update on the ongoing outages

unplanned outages and network faults



7



What new functionality would you be interested in?

Interface arrangements
with NGET

Don't currently use portal
- excited to try it!



What does the portal offer you over the email notifications sent out weekly?

Timescales greater than 8 weeks

Don't currently use portal - excited to try it!

Points of contacts

Portal gives email updates for changes

can view multiple sites in one place

more detail on the nature of the outage



2



Any questions

?



Electricity
Distribution

Distributed Generator Owner / Operator Forum

2024 objective setting

Hannah Stanley
Stakeholder manager
Regen



Please rank the following areas of interest for the upcoming 2024 workshops.

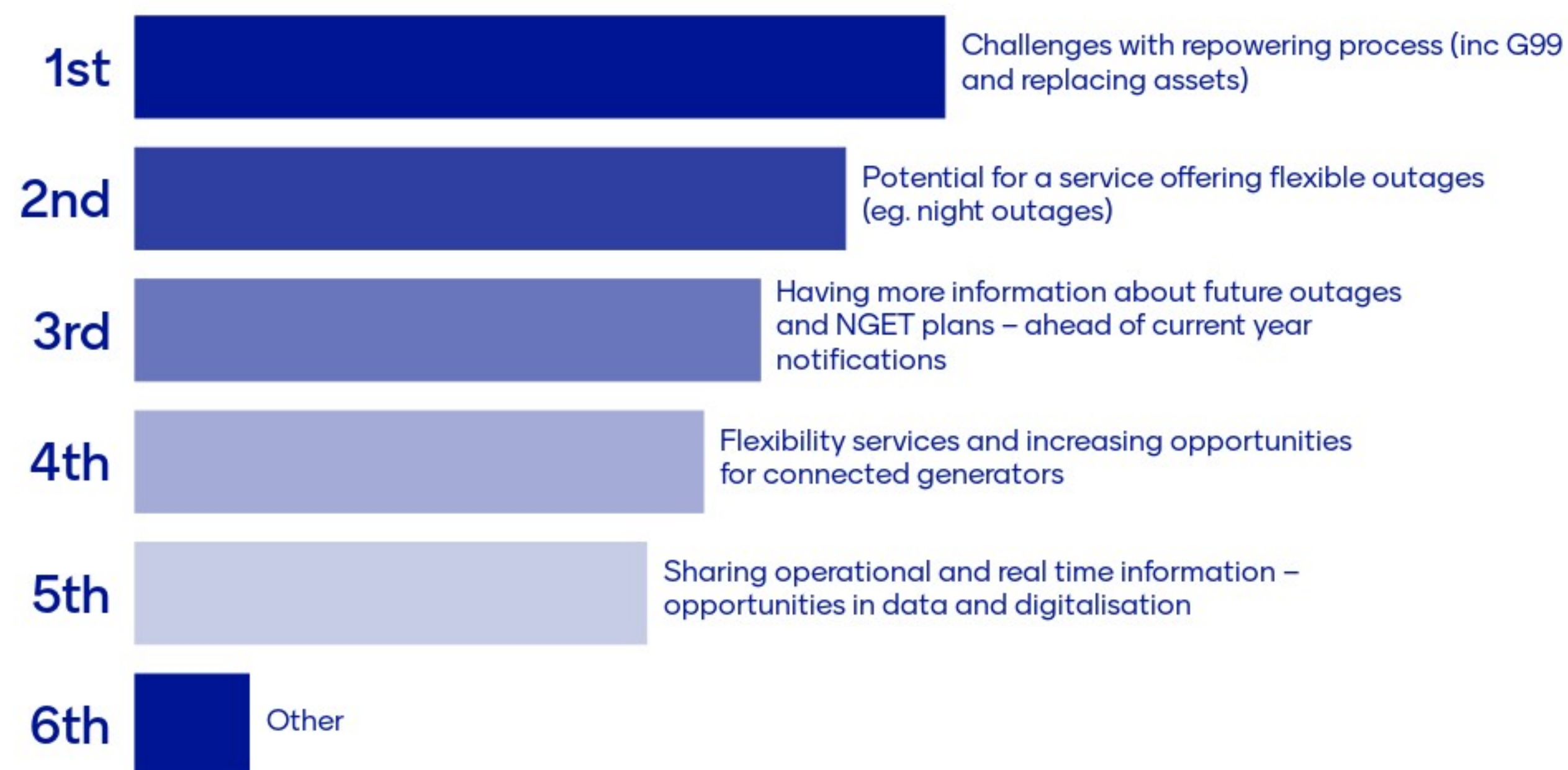

Are you facing any operational challenges that you would like to be raised or explored in the workshops for this forum?

Asset failure and spares sharing

Onboarding new rooftop sites
- difficulties with assigning export MPANs

1



2



Upcoming Forums

Tuesday 9 July, 14.00-17.00

In person, Osborne Clarke's office in London – [book here](#)

Wednesday 18 September, 14.00-15.00

Online check in – [book here](#)

Thursday 21 November, 14.00-17.00

In person, Osborne Clarke's office in Bristol – [book here](#)

How useful have you found this session?

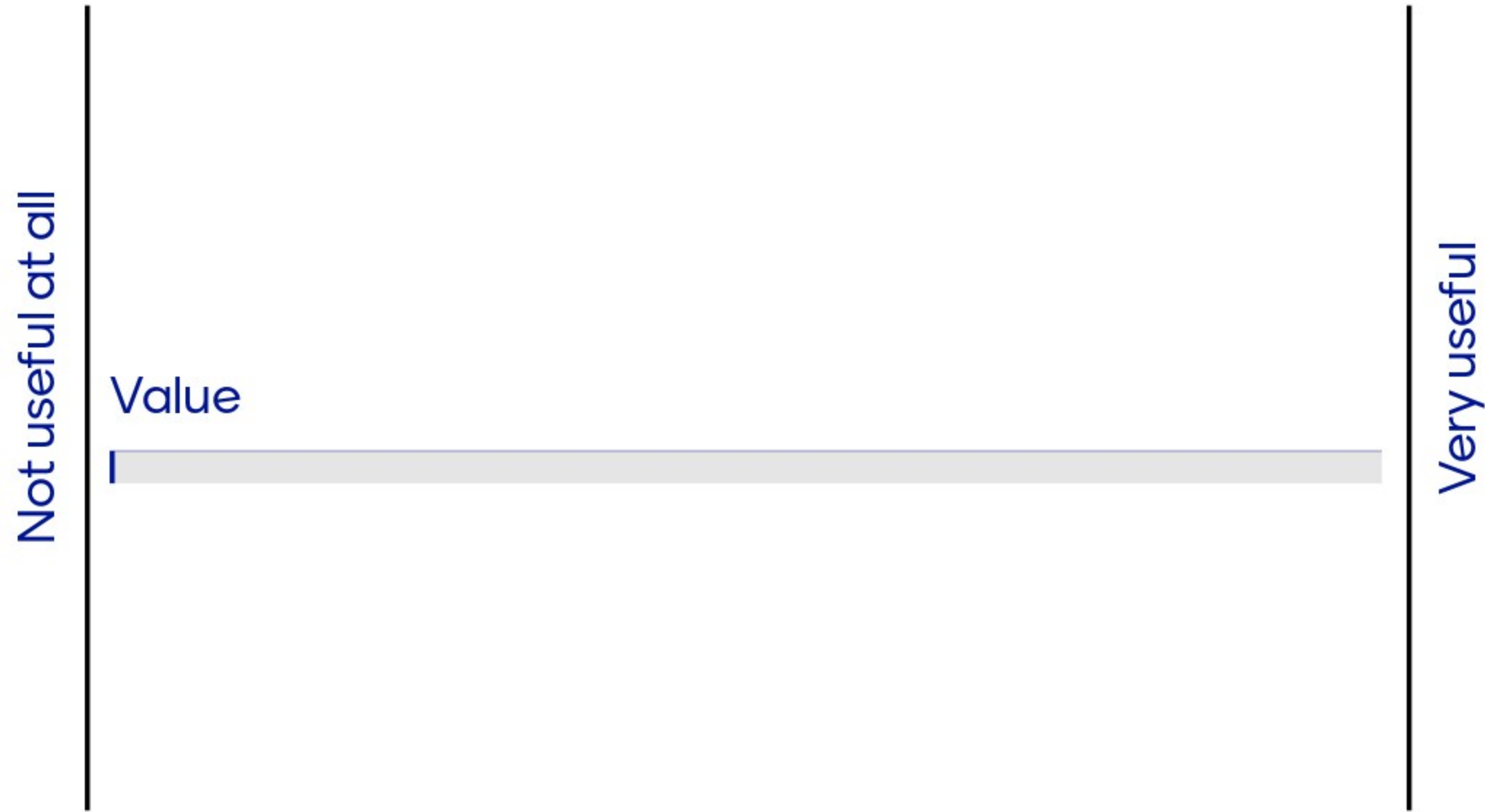

Electricity
Distribution

Distributed Generator Owner / Operator Forum

Thank you for joining us

nationalgrid

regen 
transforming energy

